

A SIP Perspective on 3GPP

ComVerse User Forum
Deauville, France

13 September 2001

Jörg Ott
jo@ipdialog.com

Overview

- SIP Reminder
- SIP Today and Tomorrow
- Service Creation with SIP
- SIP and 3GPP
- ipDialog's Support for Flexible Endpoints
- Conclusion

Session Initiation Protocol (SIP)

- Initiate, terminate, and modify sessions
 - Multimedia(!) sessions (*not voice-centric!*)
 - Point-to-point and multiparty
- Support for
 - caller and callee authentication / call authorization
 - privacy for call signaling and media streams
 - media path with ensured QoS
 - policy-based control mechanisms
- Hooks for service creation
 - end-to-end principle (“dumb network”)

3

ipDialog, Inc.

13 September 2001

Sample SIP System Architecture

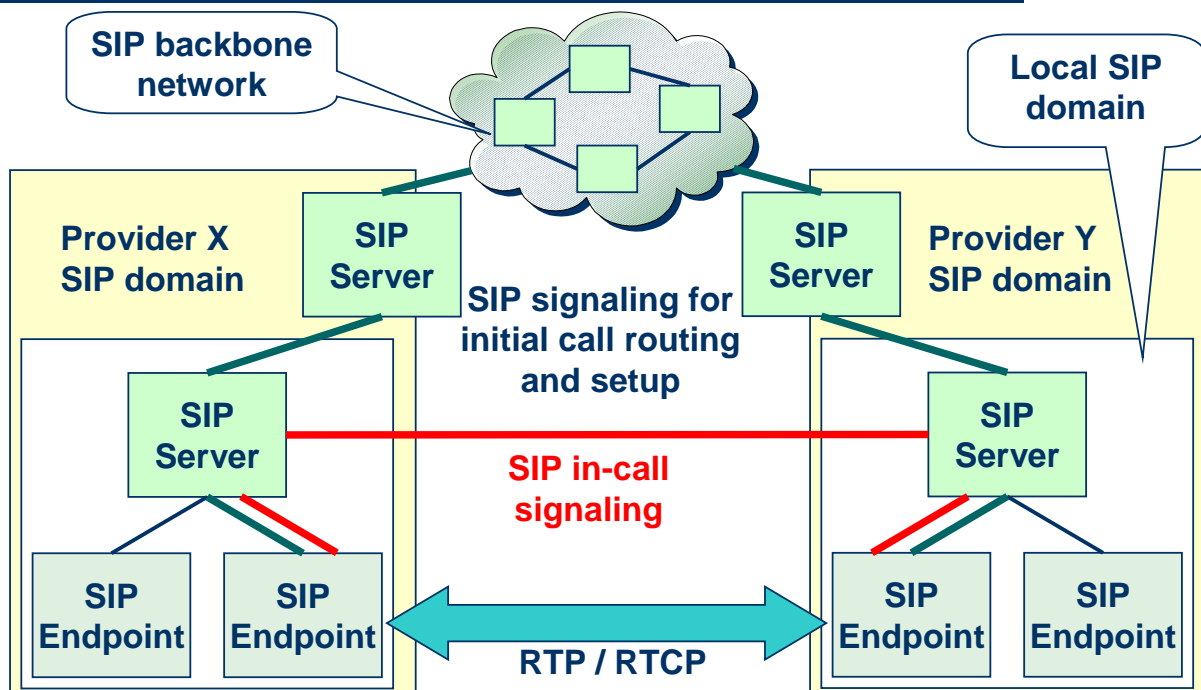

4

ipDialog, Inc.

13 September 2001

A Simple SIP Call

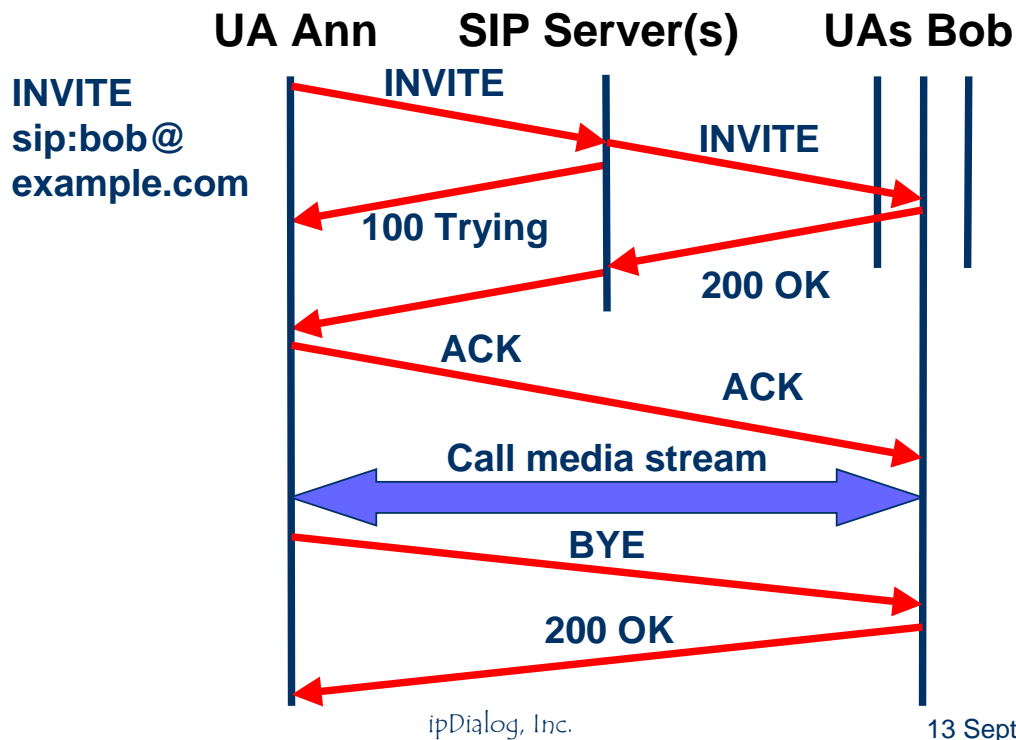

Service Creation with SIP

- Points of Service in SIP
 - Endpoints!
 - SIP Servers (proxies, redirect, location servers, ...)
 - SIP Application Servers
 - Back-to-Back User Agents
- May be located anywhere
 - in the “network”, controlled by the service provider
 - “outside the network”, controlled by third party providers
 - at the “user premises”, controlled by the user
 - and any combination of the above!
- May be combined in a flexible manner

Service Example: Conferencing

- Provider 1 offers highly available conference booking services
 - contracts with 2 – 5
- Providers 2 – 4 offer conference bridges with different capabilities
- Provider 5 offers IP Telephony Services
 - gets value add from P1
 - but also contracts others

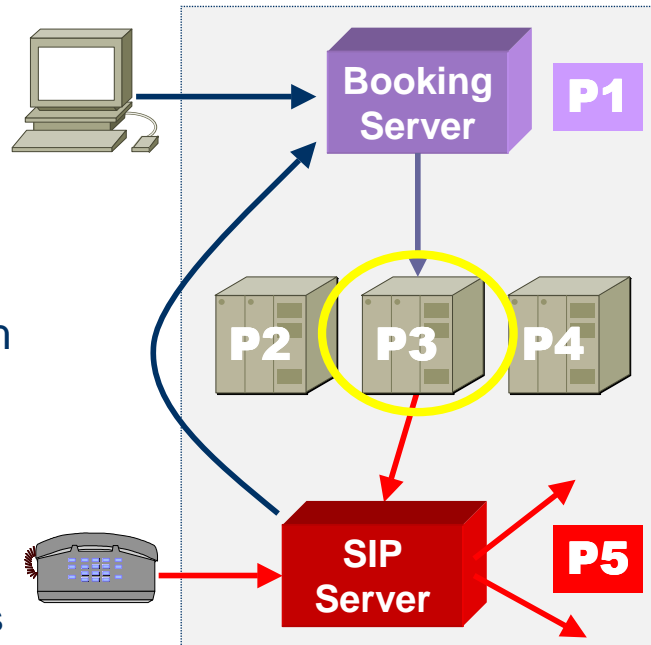

7

ipDialog, Inc.

13 September 2001

SIP Family Tree: Working Group(s)

- MMUSIC
 - Developed SIP from Feb 1996 to Feb 1999
 - Still takes care of SDP and SDPng
- SIP
 - Initiated in Oslo (Sep 1999) for “load balancing”
 - Look after the base spec + core protocol extensions
- SIPPING
 - Initiated in Minneapolis (Mar 2001) – same reason
 - First meeting at London IETF in Aug 2001
 - Work on applications of SIP: **incl. 3GPP**

8

ipDialog, Inc.

13 September 2001

SIP Today

RFC 1889: Real-time Transport Protocol (RTP)

RFC 1890: RTP Profile for Conferencing

RFC 2198: Redundancy for RTP

RFC 2327: Session Description Protocol (SDP)

RFC 2543: Session Initiation Protocol (+ bis-03)

RFC 2824: Call Processing Language Framework (CPL)

RFC 2833: Tones over RTP (“DTMF”)

RFC 2976: The SIP INFO Method

RFC 3050: SIP CGI

RFC 3087: SIP Request-URIs for Service Control

RFC 3108: ATM for SDP

SIP to come (incomplete)

- Reliable Provisional Responses (PRACK)
- Establish preconditions (COMET)
- Events (SUBSCRIBE, NOTIFY)
- SIP (and RTP/RTCP) Extensions for NATs and Firewalls
- Call Control and Conferencing
- Privacy & Security
- SIP MIB
- Interworking: SIP-T, H.323
- Autoconfiguration
- SIP Server Features
- Caller preferences, Call Processing Language
- Also: SIP for Presence and Instant Messaging

SIP and 3GPP

- 3G networks offer two modes of operation:
 - circuits and packets
- Multimedia functionality based on packets
 - IP Multimedia (IM) in the Core Network (CN)
 - (exception: H.324 used for video telephony)
- IM uses SIP for signaling
 - one piece out of a number of IETF protocols
- In the long run, all services shall converge to IP

But what does this mean?

11

ipDialog, Inc.

13 September 2001

SIP-related Components in 3GPP

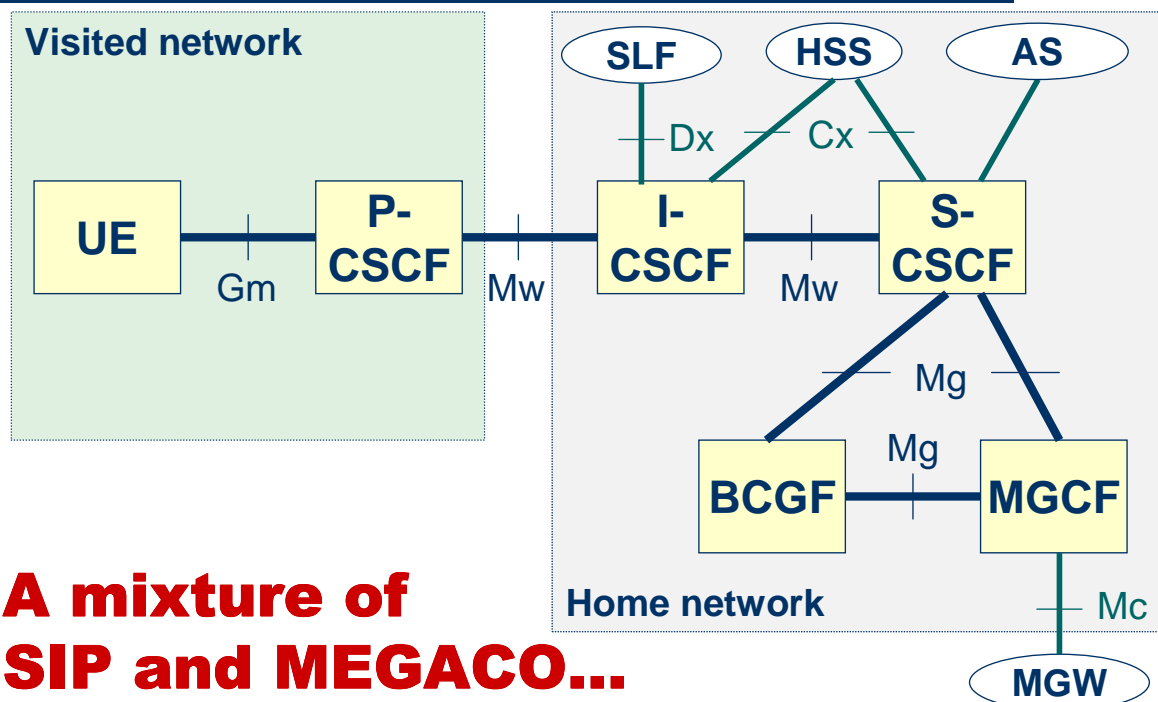

**A mixture of
SIP and MEGACO...**

12

ipDialog, Inc.

13 September 2001

SIP Components in 3GPP

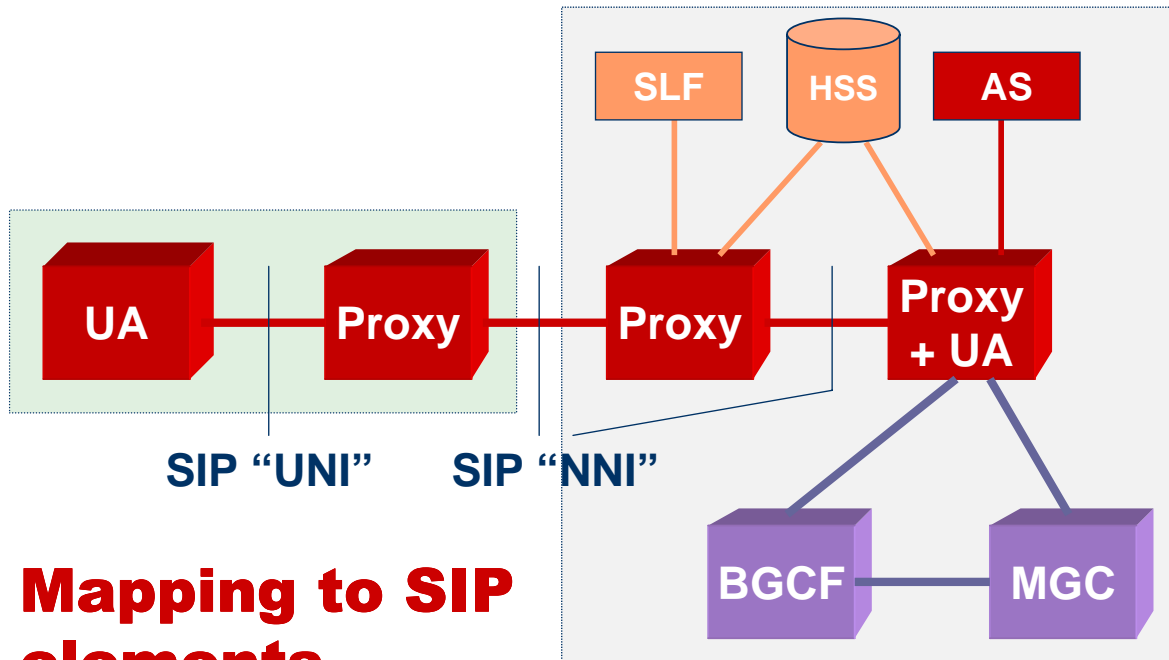

Mapping to SIP elements...

13

ipDialog, Inc.

13 September 2001

3G Control and Media Flows

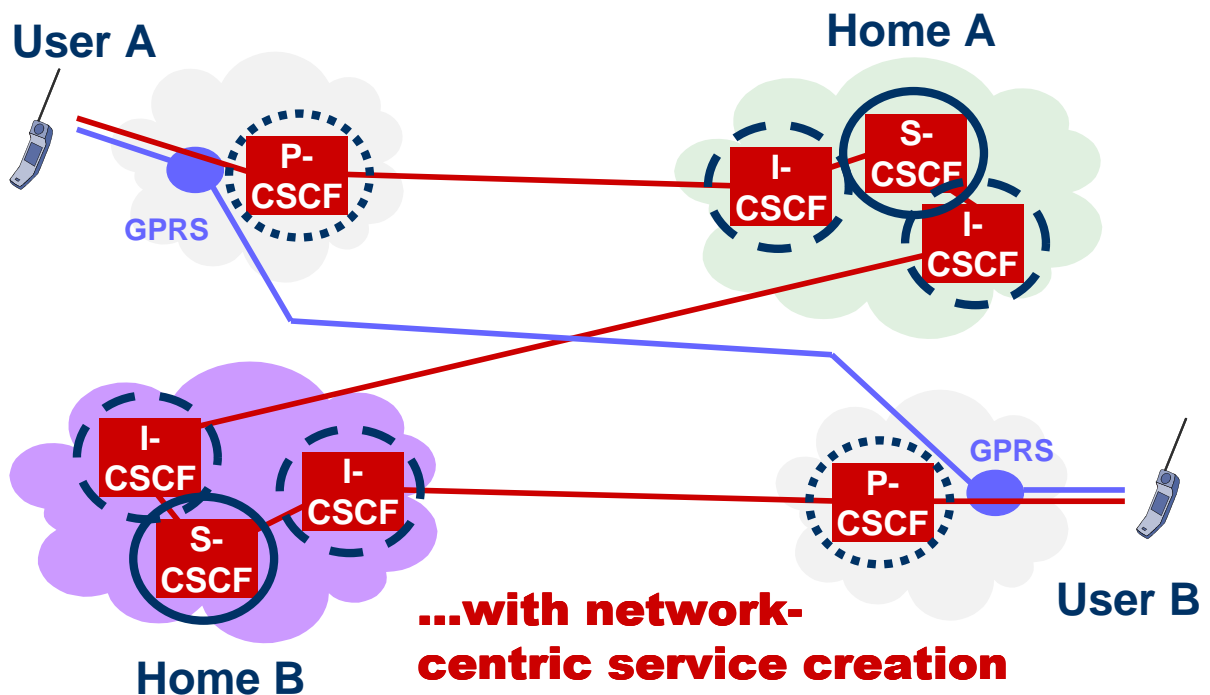

14

ipDialog, Inc.

13 September 2001

Service creation in 3GPP

- Protocol building blocks in the network
 - services to be created on top of those
- “APIs” for service providers
 - OSA, CAMEL, ...
- SIP for interfacing to Application Servers
- Numerous standardized services / functions
- Service creation in the network
 - potential for limited outside access

15

ipDialog, Inc.

13 September 2001

3GPP Summary

3G is built the *old* way – the telephony way...

- Breaks the IP end-to-end model
- Encourages net-centric service creation
 - built-in limitation of innovation
- Closed architectural model
 - built-in gateways
- Many boxes, many lines, many interfaces
 - quite some complexity to be managed

Success or “yet another ATM”...?

16

ipDialog, Inc.

13 September 2001

3GPP - SIP - Dependencies

- Next revision of SIP spec
- Extensions to core spec
 - Reliable provisional responses, state cookies, ...
- Session Timer
- Security and privacy extensions, AAA
- Resource (QoS) management
- Supplementary services
- SIP Events
- Interworking: SIP-T and H.323

17

ipDialog, Inc.

13 September 2001

How to deal with these...?

- SIP is defined exclusively in the IETF
- No changes/extensions through 3GPP
 - ensure to have only a single flavor of SIP
- Feed **requirements** into IETF SIPPING WG
 - may include suggested solutions
- SIPPING will react and define solutions
 - awareness of tight 3GPP schedule
- Possibly hand-over work to SIP WG
 - if changes/extensions to the core spec needed

18

ipDialog, Inc.

13 September 2001

Enabling SIP Endpoints...

- 3GPP endpoints speak SIP
- Requirement for endpoints:
Light-weight, extensible Protocol Stacks

ipDialog offers:

- SIP and MEGACO stacks suitable for 3G
 - flexible, extensible, proven interoperability
- Reference design for endpoints
- Support for Multi-Protocol Environments

19

ipDialog, Inc.

13 September 2001

ipDialog Firmware Architecture

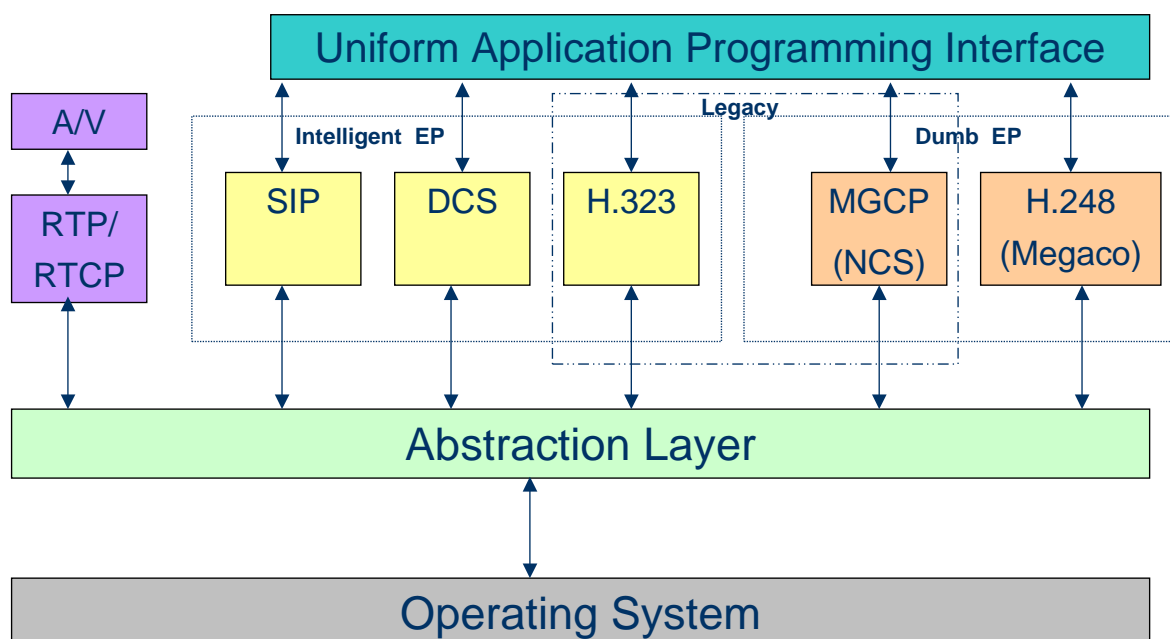

20

ipDialog, Inc.

13 September 2001

ipDialog Multiprotocol Endpoint



- Hardware reference design
- SIP *and* MEGACO
- Supports autoconfiguration
- Basic phone functions
- SIP URLs and E.164 numbers
- Business feature set in progress
 - simple software updates
- Customization
 - different cases, displays, keypads
 - more sophisticated functionality
- Can “turn” into a 3G endpoint as well!

21

ipDialog, Inc.

13 September 2001

Conclusion

SIP standardization progressing rapidly

- An enabling platform for a ubiquitous open environment

But: future-proof specifications take their time

- Possible gains through outside pressure limited
- Isolated outside development is **not an option!**

SIP is the perfect infrastructure for 3G networks

- However, choosing SIP is necessary but not sufficient.
- It also needs to be applied appropriately
- Continued joint efforts between IETF and 3GPP...

22

ipDialog, Inc.

13 September 2001

Further Information

<http://www.ietf.org/html.charters/sip-charter.html>

<http://www.greycouncil.com/sipwg>

<http://www.greycouncil.com/sippingwg>

<http://www.cs.columbia.edu/~hgs/sip>

<http://www.cs.columbia.edu/~hgs/sip/sipit>

ftp://ftp.3gpp.org/Specs/Latest_drafts/

<ftp://ftp.3gpp.org/Specs/2001-06/Rel-5>

<http://www.ipdialog.com/>